

A matter of experience.

N&W has been developing and producing automatic beverage dispensers for many years and supplies over 100 countries. This market leadership has been achieved and maintained by investing heavily in research and development and is the result of many years of technical and manufacturing experience, combined with a passion for innovation and design.

N&W products are developed and produced using processes approved to two internationally recognised standards, one for quality - UNI EN ISO 9001:2008 - Valbrembo, Mozzo, Odense and Bilston sites, and one for the environment - UNI EN ISO 14001 - Valbrembo and Mozzo sites.

N&W is committed to providing the market with first-class high quality products and the quality certification of all its plants underlines this significant commitment. With regard to the environment, N&W has always paid great attention to the environmental impact of its products and processes and continuously strives to keep this to a minimum.

A further important certification achieved by N&W is supplied by IMQ, Istituto Italiano del Marchio di Qualità (Italian Quality Trademark Institute). This certification assures all N&W products meet the home appliance safety standards as well as the safety standards for commercial dispensers.

**GREENER
BY NATURE**



N&W GLOBAL VENDING S.p.A.
Via Roma 24 - 24030 Valbrembo (BG) - Italy
Ph. +39 035 606 111
Fax +39 035 606 463

www.nwglobalvending.com



N&W

N&W Global Vending reserves the right to alter specifications without notice.

L252U7

NECTA

**GREENER
BY NATURE**

K R O

SELECT DRINK

espresso americano café macchiato café latte cappuccino café mocha chocolate hot water

O

R

K



NECTA



Koro - a touch of class

To truly enjoy a fresh cup of coffee, we find it helps if you close your eyes, inhale, take in the aroma and then take pleasure in the taste of a great cup of coffee. It all forms part of the ritual of drinking coffee. In everyday life, at work or during free time, we always find the right moment to indulge in this great little pleasure.

The Koro dispenser comes from the technology and experience of Necta. With soft clean lines, the Koro offers typically elegant classic Italian design, aesthetically pleasing the machine provides excellent value for money yet benefits from being technically superior. Koro is extraordinarily compact and reliable, due to the use of the highest quality components, normally used in dispensers that support much heavier workloads.



Thanks to its characteristics, Koro is ideal for environments such as offices, meeting rooms, stores, professional studios, small cafés and restaurants, and can be managed in a variety of ways.

Superior technology to satisfy every need

If it's style and sophistication you're looking for, Koro has the answer. Thanks to the different technologies for preparing drinks, Koro represents the ideal solution for a hot drinks service of high quality, with a menu to satisfy every taste.



Espresso

Thanks to the patented coffee group, the volumetric doser and the perfect extraction according to the parameters of the best Italian espresso, Koro offers excellent coffee and mixed beverages, including a wonderful cappuccino.



Fresh Brew

The Sigma Brewer (patented) guarantees very high quality beverages, through the high extraction of the coffee and tea.



Instant

The mixers produce a first-rate drink with a good emulsion and perfect crème.

Simple and stylish

Style and simplicity are synonymous with the Koro and its ease of use is down to the simple display and conveniently situated buttons, directing the user in their choice of preferred beverage. Koro has a wide selection menu and can offer up to eight different drinks, and through its versatility it is at home in any situation. The Koro is incredibly small (only 20 inches/50 cm high) and light, making it easy to position and move.

Easy maintenance and cleaning

The Koro's cleaning and maintenance system is simplicity itself. The optimisation of the mixer's parts (only three components), the suction of dust through a small built-in drawer, and the dust conveyor make cleaning operations quick and simple. Mixers are easy to remove by using the green coloured release system. The Sigma brewer in the fresh brew version is easily removable without tools and can be completely disassembled and cleaned. It also has a special filter perfect both for coffee and tea based beverages.

Accessories

- In order to suit every client's requirements, a complementary range of accessories is available including:
- Super-equipped base cabinet with solid and liquid waste containers plus cups/sugar/stirrers holders
 - Payment system module
 - Cup holder module
 - Cup warmer
 - 20 lt. water self feeding tank (only when ordered with base cabinet)
 - Water filter kit



- We were first in the business to achieve ISO 14001
- We lead the way with lean, green production processes
- Avex 2007 Awards Best Sustainability award
- Vending Paris 2008 Awards Best Sustainable Development & the Environment
- We apply Life Cycle Product Design
- We adhere to a stringent Environmental Management System
- We adopt product Life Cycle Assessment
- We're proud to be a member of the EMP committee

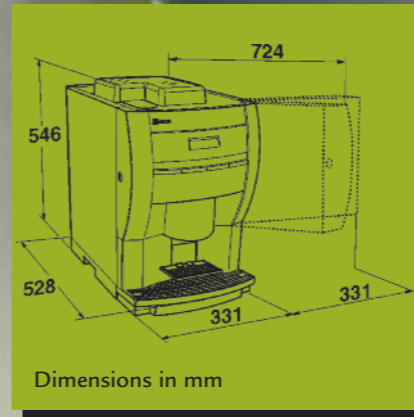

GREENER BY NATURE



Espresso

Drinks delivered	Espresso Americano Black Coffee Café macchiato Café latte Cappuccino White Coffee Hot Water
Hourly output	70 espresso coffee 60 cappuccinos 100 chocolates 10 litres of hot water
Ingredients capacity	Coffee beans 0.35 kg Coffee bean ext. 0.75 kg Soluble coffee 0.25 kg Whitener 0.65 kg Chocolate 0.65 kg
Weight	27 kg
Appr. number of coffees before refilling	100 cups

Instant

Drinks delivered	Espresso Americano Café macchiato Café latte Cappuccino Café mocha Chocolate Hot water
Hourly output	120 cups 80 cappuccinos 100 chocolates 31 litres of hot water
Ingredients capacity	Soluble coffee 0.25 kg Whitener 0.65 kg Chocolate 0.65 kg
Weight	27 kg
Appr. number of coffees before refilling	150 cups

Fresh Brew

Drinks delivered	Filtered black coffee Stronger filtered black coffee Filtered white coffee Café latte Cappuccino Café mocha Chocolate Hot water
Tea version	Black leaf tea Stronger black leaf tea White leaf tea Espresso Americano Café latte Cappuccino Hot water
Hourly output	150 cups 80 cappuccinos 100 chocolates 31 litres of hot water
Ingredients capacity	Ground coffee 0.35 kg Freshbrew tea 0.4 kg Soluble coffee 0.25 kg Whitener 0.65 kg Chocolate 0.65 kg
Weight	27 kg
Appr. number of coffees before refilling	50 cups

