

## A matter of experience.

N&W has been developing and producing automatic beverage dispensers for the Out-of-Home and Catering sectors for many years and supplies over 100 countries. This market leadership has been achieved and maintained by investing heavily in research and development and is the result of many years of technical and manufacturing experience, combined with a passion for innovation and design.

Necta HoReCa products are developed and produced using processes approved to two internationally recognised standards, one for quality - UNI EN ISO 9001:2008 - and one for the environment - UNI EN ISO 14001:2004. N&W is committed to providing the market with first-class high quality products and the quality certification of all its plants underlines this significant commitment. With regard to the environment, N&W has always paid great attention to the environmental impact of its products and processes and continuously strives to keep this to a minimum.

A further important certification achieved by N&W is supplied by IMQ, Istituto Italiano del Marchio di Qualità (Italian Quality Trademark Institute). This certification assures all N&W products meet the home appliance safety standards as well as the safety standards for commercial dispensers.

**GREENER  
BY NATURE**



N&W GLOBAL VENDING Ltd.  
Dudley Street - Bilston  
West Midlands WV14 0LA  
Ph. +44 (0)1902 355 000  
Fax +44 (0)1902 355 017

[www.nwglobalvending.co.uk](http://www.nwglobalvending.co.uk)

N&W GLOBAL VENDING S.p.A.  
Via Roma 24 - 24030 Valbrembo (BG) - Italy  
Ph. +39 035 606 111  
Fax +39 035 606 519



N&W Global Vending reserves the right to alter specifications without notice.

L252K0

NECTA

**GREENER  
BY NATURE**

K O R O



O

R

E



**NECTA**





## Koro and Koro Max, a touch of class.

To truly enjoy a fresh cup of coffee, we find it helps if you close your eyes, inhale, take in the aroma and then take pleasure in the taste of a great cup of coffee. It all forms part of the ritual of drinking coffee. In everyday life, at work or during free time, we always find the right moment to indulge in this great little pleasure.

The Koro and Koro Max comes from the technology and experience of Necta. With soft clean lines, the Koro and Koro Max offer typically elegant classic Italian design, aesthetically pleasing the machines provide excellent value for money whilst benefiting from being technically superior. Koro and Koro Max are extraordinarily compact and reliable, due to the use of the highest quality components, normally used in machines that support much heavier workloads.

Thanks to its characteristics, Koro and Koro Max are ideal for environments such as offices, meeting rooms, stores, professional studios, small cafés and restaurants, and can be managed in a variety of ways.

## Superior technology to satisfy every need

If it's style and sophistication you're looking for, Koro and Koro Max have the answer. Thanks to the different technologies for preparing drinks, Koro and Koro Max represent the ideal solution for hot drinks services of a superior quality, with a menu to satisfy every taste.

### Espresso

Thanks to the patented coffee group, the volumetric doser and the perfect extraction according to the parameters of the best Italian espresso, Koro and Koro Max offer excellent coffee and a variety of other hot beverages, including a wonderful cappuccino. While the Koro Max has an additional canister for chocolate.

## Simple and stylish

Style and simplicity are synonymous with the Koro and Koro Max, and its ease of use is down to the simple display and conveniently situated buttons, directing the user in their choice of preferred beverage. Koro and Koro Max have a wide drinks menu and can offer up to eight different drinks, and through their versatility they are at home in any situation. The Koro and Koro Max are also small in size and light, making them easy to position into location and move around.

## Easy maintenance and cleaning

The cleaning and maintenance system in the Koro and Koro Max is simplicity itself. The optimisation of the mixer's parts (only three components), the suction of dust through a small built-in drawer, and the dust conveyor make cleaning operations quick and simple. Mixers are easy to remove by using the green coloured release system.

## Accessories

In order to suit every client's requirements, a complementary range of accessories is available including:

- Super-equipped base cabinet with solid and liquid waste containers plus cups/sugar/stirrers holders
- Payment system module
- Cup holder module
- Cup warmer
- 20 litre water self feeding tank (only when ordered with base cabinet)
- Water filter kit



**GREENER  
BY NATURE**

- We were first in the business to achieve ISO 14001
- We lead the way with lean, green production processes
- Avex 2007 Awards Best Sustainability award
- Vending Paris 2008 Awards Best Sustainable Development & the Environment
- We apply Life Cycle Product Design
- We adhere to a stringent Environmental Management System
- We adopt product Life Cycle Assessment
- We're proud to be a member of the EMP committee

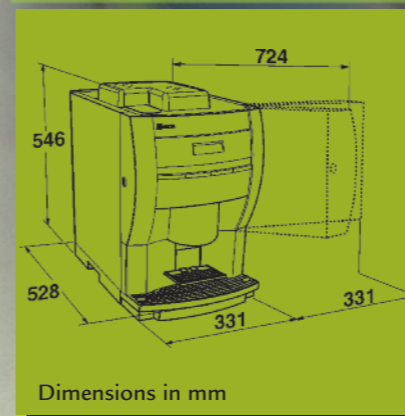

Dimensions in mm

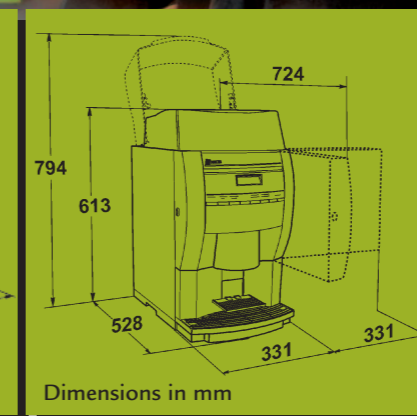

Dimensions in mm

### KORO Espresso

#### Drinks delivered

Espresso  
Americano  
Black Coffee  
Caffè Macchiato  
Caffè Latte  
Cappuccino  
White Coffee  
Hot Water

#### Ingredients capacity

Coffee beans 0.75 kg  
Whitener 0.65 kg

#### Weight

27 kg

#### Approx No. of coffees before refilling

100 cups

### KORO MAX Espresso

#### Drinks delivered

Espresso  
Americano  
White Coffee  
Cappuccino  
Caffè Latte  
Caffè Mocha  
Hot Chocolate  
Hot water

#### Optional replaces one of the other selections

Chocomilk

#### Ingredients capacity

Coffee beans 1.0 kg  
Whitener 0.75 kg  
Chocolate 1.5 kg

#### Weight

30 kg

#### Approx No. of coffees before refilling

130 cups

Both Koro and Koro Max are available in two versions:

- Plumbed
- 3.5 litre internal tank